

TRANSMITTER T3419

**Programmable transmitter of temperature, relative humidity
and other derived humidity values with RS485 serial output
and external probe**

Instruction Manual

Instruction Manual for use of temperature and relative humidity transmitter T3419

Transmitter is designed for measurement of ambient temperature and relative humidity of air without aggressive ingredients with computing one of the following values: dew point temperature, absolute humidity, specific humidity, mixing ratio and specific enthalpy. Please read instruction manual before the first transmitter connection. Transmitter communicates via link RS485. Supported communication protocols are Modbus RTU, protocol compatible with standard Advantech-ADAM and ARION. Temperature and relative humidity sensors are non-removable instrument parts. Measured and computed values are displayed on dual line LCD display. The first line displays temperature. Value displayed on the second line is selectable among relative humidity and computed value. It is also possible to display both readings with cyclic overwriting in 4 seconds interval. Display can be also switched OFF totally. Output link RS485 is **galvanic isolated**. Setting of all transmitter parameters is enabled in accordance with procedure described in chapter „*Setting of transmitter, selection of communication protocol*“ or by means of commands of selected communication protocol.

Transmitter setting from the manufacturer

If special setting was not required in the order transmitter is set from the manufacturer to the following parameters:

communication protocol:	Modbus RTU
transmitter address:	01H
communication speed:	9600Bd, without parity, 2 stop bits
display:	switched ON
value displayed at lower line:	relative humidity only
preset computed value:	dew point temperature

Transmitter installation

Transmitter is designed for wall mounting. There are two mounting holes at the sides of the case. It is NOT recommended to use the probe for long time under condensation conditions. It could be the cause of water steam condensation inside the sensor's cover into water phase. This liquid phase stays inside sensor's cover and can't escape from the cover easily. It can dramatically increase response time to relative humidity change. If water condensation occurs for longer time it can cause sensor damage. Similar effect can occur under water aerosol conditions. If this effect may occur, it is necessary to use the probe at operation position with sensor cover downwards. Don't connect transmitter while power supply voltage is on. Interconnection terminals are accessible after unscrewing four screws and removing the lid. Measuring temperature and relative humidity sensors are non-removable instrument parts. Lace the cable through a gland at the case wall. Connect the cable to terminals with respecting the signal polarity (see figure). Terminals are self-clamping and can be opened by a suitable screwdriver. For the opening, insert the screwdriver to smaller terminal hole and lever by him. Do not forget to tighten glands and case lid with inserted packing after cables connecting. It is necessary for warranting of protection IP65.

It is recommended to use shielded twisted copper cable (e.g. SYKFY). Outside diameter of the cable must be from 3 to 6.5 mm, maximal length 1200m. The cable must be located at indoor rooms.

Nominal cable impedance should be 100 Ω , loop resistance max. 240 Ω , cable capacity max. 65 pF/m. Suitable cable is e.g. SYKFY 2x2x0,5 mm², where one wire pair serves for transmitter powering and the other pair for communication link.

The cable should be led in one line, i.e. NOT to „tree“ or „star“. Termination resistor should be located at the end. For short distance other topology is allowed. Terminate the network by a termination resistor. The value of the resistor is recommended about 120 Ω . For short distance termination resistor can be left out.

The cable should not be led in parallel along power cabling. Safety distance is up to 0.5 m, otherwise undesirable induction of interference signals can appear.

Dimensions

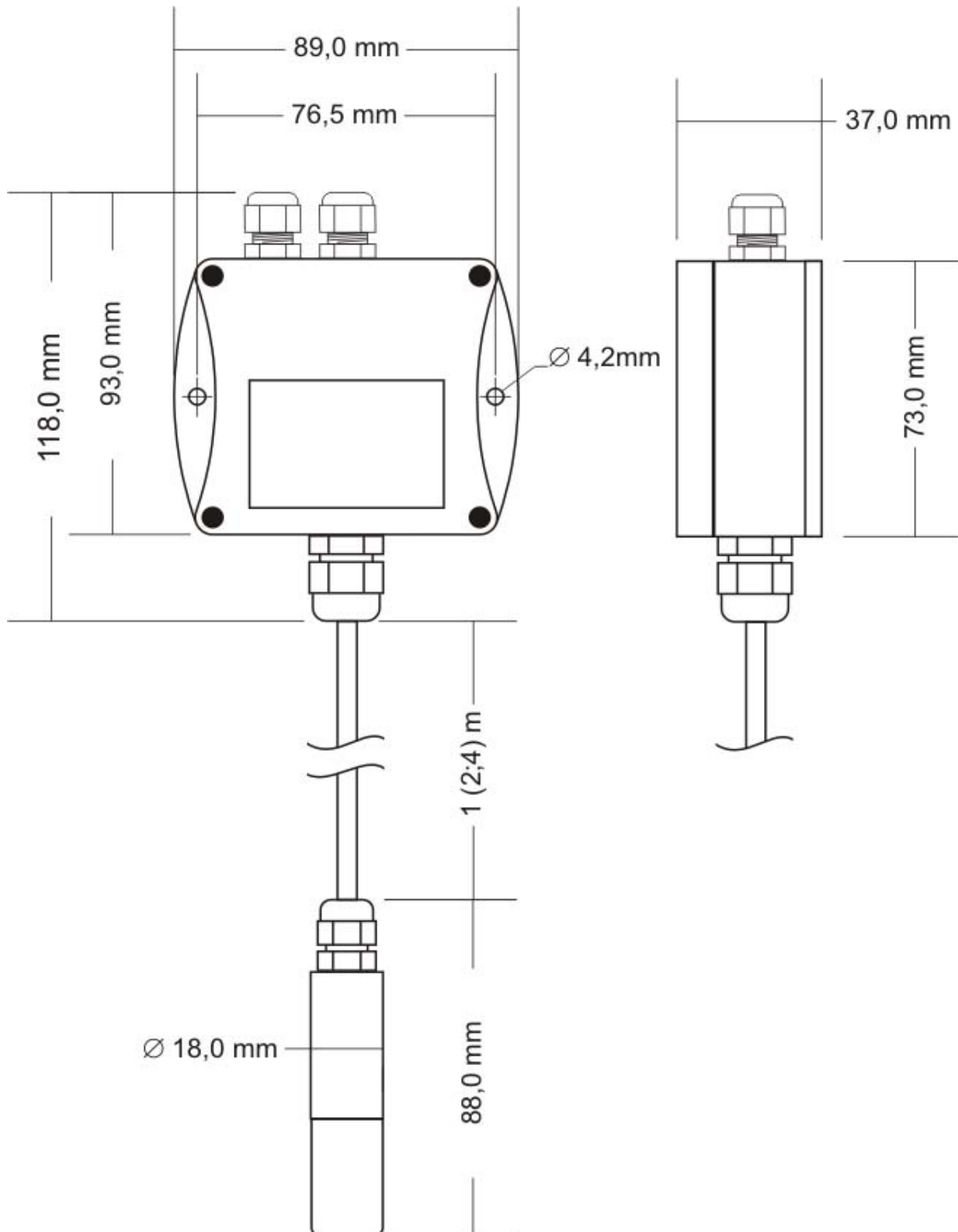

Typical application wiring, connection of terminals

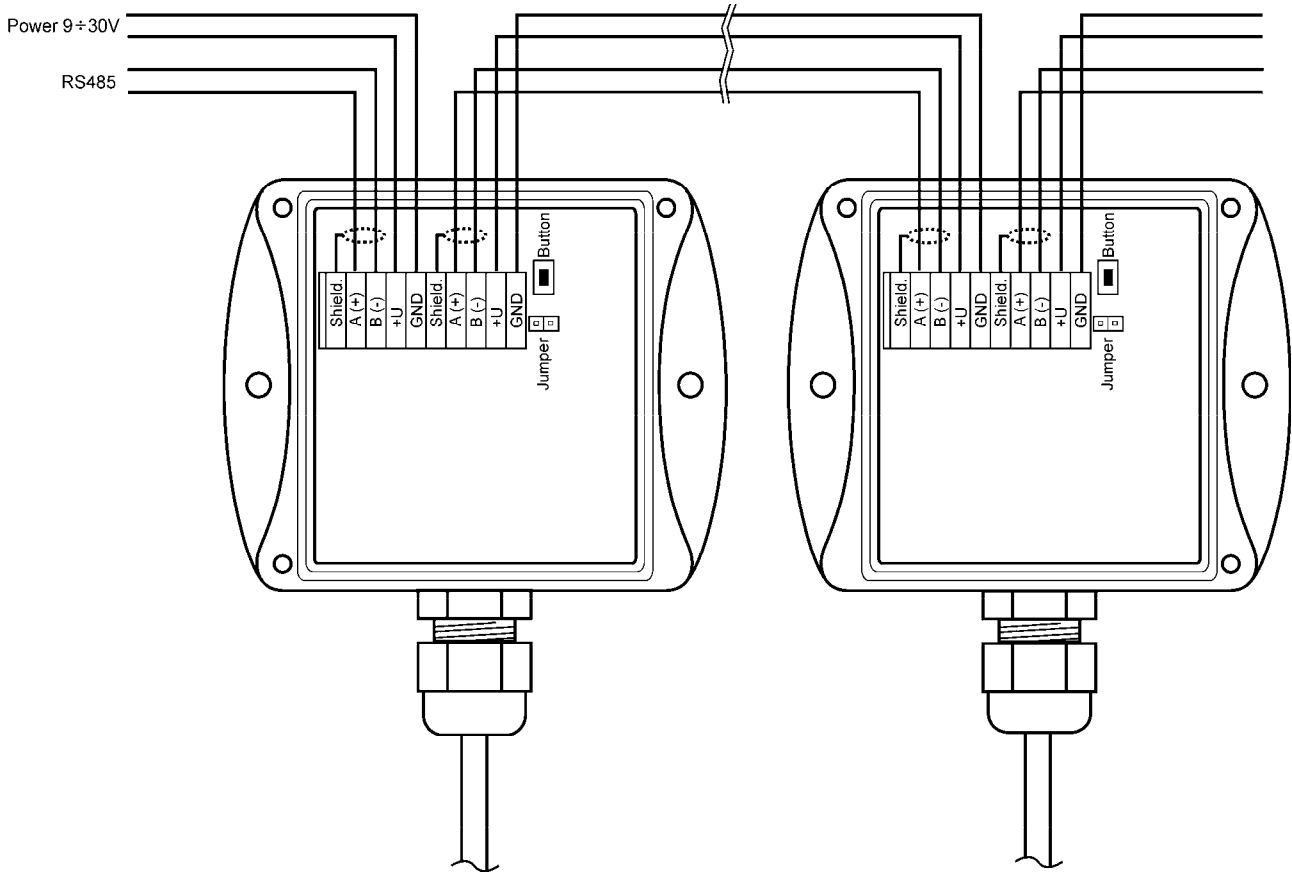

Info mode

If in doubt of setting of installed transmitter, verification of its address is enabled even without using computer. Power should be connected.

Unscrew transmitter cover and shortly press button next to connection terminals (jumper should be opened). Actual adjusted address of transmitter is displayed on LCD display at decimal base. Next press of button exits info mode and actual measured values are displayed.

Note: No measurement and communication is possible during info mode. If transmitter stays in info mode for longer than 15 s, transmitter automatically returns to measuring cycle.

Setting of transmitter, selection of communication protocol

Each new setting of transmitter parameters is stored in its internal memory¹. If modification of transmitter setting is needed (communication protocol, its parameters, setting of LCD display), it is recommended to use of User's software available at www.cometsystem.cz (providing all settings of transmitter parameters) or proceed in following way (support basic setting):

- Connect transmitter with PC (use converter RS485/RS232 RS232 with automatic switching control).

¹ During writing to transmitter memory no power failure should appear! Such failure can cause damage of other settings stored in the transmitter!

- Run program „HyperTerminal“ on your computer – it is a part of Windows operating system (Start → Program Files → Accessory → Communication → HyperTerminal) and set transmission parameters. I.e. enter name of new connection (e.g. Transmitter), press button OK, window „Connect“ appears. In field „Connect by means of“ select COM port, which transmitter is connected to (e.g. COM1) and press OK. In following window „COM1 – Properties“ enter to field:

„Bits per second“ **9600**
 “Data bits“ **8**
 “Parity“ **None**
 “Number of stop-bits“ **1**
 “Flow control“ **None**
 Continue by pressing OK.

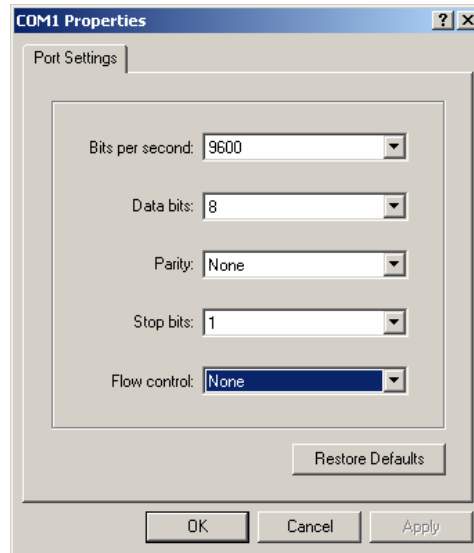

- Select item „File“, „Features“ in menu. Select bookmark „Setup“, in the window, click on „ASCII Setup... “ and modify all items in accordance with following figure and press OK

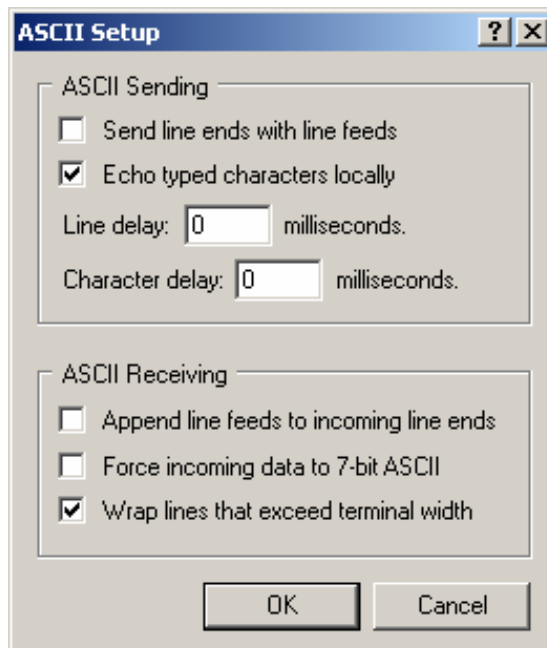

- Unscrew 4 screws of transmitter cover and remove it. Plug in jumper.
- Keep the button inside the transmitter pressed, only now you can connect power voltage and then release the button.
- LCD display of the transmitter displays „PC“.

- Running HyperTerminal displays main menu,

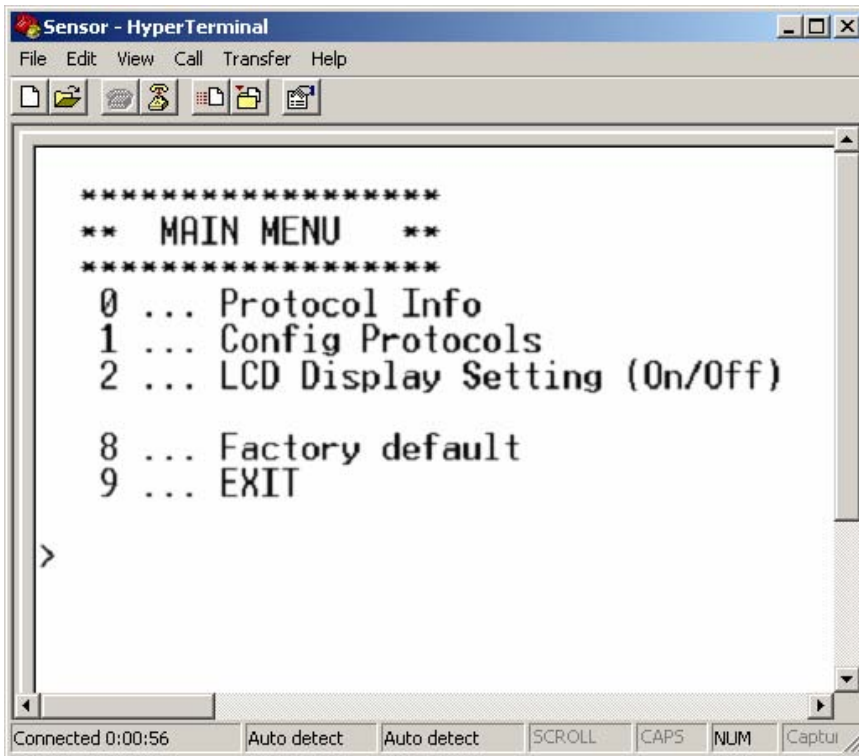

Select required items to set the transmitter:

- 0 ... Displays actual setting of the transmitter
- 1 ... Selection of communication protocol and setting of its parameters (transmitter address, communication speed...). For entering numeric values use digits 0 to 9 and characters „A“ to „F“ (upper case letters), transmitter address is entered always as two digits hexadecimal number (no decimal, e.g. address 11 i.e. Bh must be entered as 0B).
- 2 ... Setting of LCD display of the transmitter (display switched ON/ switched OFF, selection of displayed values)
- 8 ... Setting communication to default value from manufacturer (Modbus, address 01h, 9600 Bd)
- 9 ... End of setting

All changes in setting are continuously stored automatically.

- If needed close transmitter again with cover.

Description of communication protocols

Detailed description of each communication protocols including examples of communication is available in individual document “*Description of communication protocols of Txxx series*” which is free to download at www.cometsystem.cz.

To change communication protocol use User’s software or proceed in accordance with chapter „*Setting of transmitter, selection of communication protocol*“

Note: After switching ON the power of the transmitter it can last up to 2 s before the transmitter starts to communicate and measure!

Modbus RTU

Control units communicate on master-slave principle in half-duplex operation. Only master can send request and only addressed device responds. During sending of request no other slave station should respond. During communication, data transfer proceeds in binary format. Each Byte

is sent as eight bit data word in format: 1 start bit, data word 8 bit (LSB first), 2 stop bits², without parity. Transmitter supports communication speed from 110Bd to 115200Bd.

Sent request and response have syntax: ADDRESS OF DEVICE – FUNCTION – Modbus CRC

Supported functions

03 (0x03): Reading of 16-bit registers (Read Holding Registers)

04 (0x04): Reading of 16-bit input gates (Read Input Registers)

16 (0x10): Setting of more 16-bit registers (Write Multiple Registers)

Jumper and button

Jumper and button are located next to connection terminals. If communication protocol Modbus is selected the function of jumper and button is as follows:

- Jumper opened – transmitter memory is protected from writing, from transmitter side it is only enabled to read measured value, writing to memory is disabled (no change of transmitter address, communication speed and LCD setting is enabled)
- Jumper closed – writing to transmitter memory is enabled by means of User's software
- Jumper closed and button pressed for longer than three seconds – causes restoring of manufacturer setting of communication protocol, i.e. sets transmitter address to 01h and communication speed to 9600Bd
- Jumper opened and button shortly pressed – transmitter goes to Info mode, see chapter „Info mode“

Modbus registers of the device

Variable	Unit	Address ^X	Format	Size	Status
Measured temperature	[°C]	0x0031	Int*10	BIN16	R
Measured relative humidity	[%]	0x0032	Int*10	BIN16	R
Computed value *	[°C]	0x0033	Int*10	BIN16	R
Address of transmitter	[-]	0x2001	Int	BIN16	R/W*
Code of communication speed	[-]	0x2002	Int	BIN16	R/W*
Serial number of transmitter Hi	[-]	0x1035	BCD	BIN16	R
Serial number of transmitter Lo	[-]	0x1036	BCD	BIN16	R
Version of Firmware Hi	[-]	0x3001	BCD	BIN16	R
Version of Firmware Lo	[-]	0x3002	BCD	BIN16	R

Explanation:

- * to choice of computed value type use User's software
- Int*10 register is in format integer*10
- R register is designed only for reading
- W* register is designed for writing, for more details see chapter description of communication protocols
- ^X register addresses are indexed from zero – register 0x31 is physically sent as value 0x30, 0x32 as 0x31 (zero based addressing)

Note: In case there is a need for reading of measured values from transmitter with higher resolution than one decimal, measured values in transmitter are stored also in „Float“ format, which is not directly compatible with IEEE754.

Protocol compatible with Advantech-ADAM standard

Control units communicate on master-slave principle in half-duplex operation. Only master can send requests and only addressed device responds. During sending request any of slave devices should respond. During communication data is transferred in ASCII format (in characters). Each

² Transmitter sends two stop bits, for receive one stop bit is enough.

Byte is sent as two ASCII characters. Transmitter supports communication speed from 1200Bd to 115200Bd, parameters of communication link are 1 start bit + eight bit data word (LSB first) + 1 stop bit, without parity.

Jumper

Jumper is located next to connection terminals. If communication protocol compatible with standard Advantech-ADAM is selected, its function is the following:

- If jumper during switching ON the power is closed, transmitter always communicates with following parameters regardless stored setting in the transmitter: communication speed 9600 Bd, without check sum, transmitter address 00h
- If jumper during switching ON the power is not closed, transmitter communicates in accordance with stored setting.
- If jumper is closed during transmitter operation, transmitter temporarily changes its address to 00h, it will communicate in the same communication speed as before closing jumper and will communicate without check sum. After jumper is opened setting of address and check sum is reset in accordance with values stored in transmitter.
- Communication speed and check sum are possible to change only if jumper is closed.

ARION communication protocol - AMiT company

The device supports communication protocol ARION version 1.00. For more details see chapter description of communication protocols.

Error States of the device

Device continuously checks its state during operation. In case error is found LCD displays corresponding error code:

Error 0

First line displays „Err0“.

Check sum error of stored setting inside device's memory. This error appears if incorrect writing procedure to device's memory occurred or if damage of calibration data appeared. At this state device does not measure and calculate values. It is a serious error, contact distributor of the instrument to fix.

Error 1

Measured (calculated) value is over upper limit of allowed full scale range. There is a reading „Err1“ on LCD display. Value read from the device is +999,9.

This state appears in case of:

- Measured temperature is higher than approximately 600°C (i.e. high non-measurable resistance of temperature sensor, probably opened circuit).
- Relative humidity is higher than 100%, i.e. damaged humidity sensor, or humidity calculation of humidity is not possible (due to error during temperature measurement)
- Computed value – calculation of the value is not possible (error during measurement of temperature or relative humidity or value is over range)

Error 2

There is a reading „Err2“ on LCD display. Measured (calculated) value is below lower limit of allowed full scale range. Value read from the transmitter is -999,9.

This state appears in case of:

- Measured temperature is lower than approximately -210°C (i.e. low resistance of temperature sensor, probably short circuit).

- Relative humidity is lower than 0%, i.e. damaged sensor for measurement of relative humidity, or calculation of humidity is not possible (due to error during temperature measurement)
- Computed value – calculation of computed value is not possible (error during measurement of temperature or relative humidity)

Error 3

There is a reading „Err3“ on LCD display upper line.

Error of internal A/D converter appeared (converter does not respond, probably damage of A/D converter). No measurements proceed. It is a serious error, contact distributor of the instrument.

Readings on LCD display

°C

Reading next to this symbol is measured temperature or error state of value.

%RH

Reading next to this symbol is measured relative humidity or error state of value.

°C DP

Reading next to this symbol is calculated dew point temperature or error state of value.

first left arrow

Is on if jumper is closed.

second left arrow

Is on if button is pressed.

On LCD display is shown the value with corresponding unit for temperature, relative humidity and dew point temperature. For rest values is shown only number (without corresponding unit).

Technical parameters of the instrument:

RS 485 Interface:

Receiver-Input Resistance: 96 k Ω

Devices on bus: max. 256 (1/8 Unit Receiver Load)

Measuring parameters:

Ambient temperature (RTD sensor Pt1000/3850ppm):

Measuring range: -30 to +105 °C

Resolution of display: 0.1 °C

Accuracy: ± 0.4 °C

Relative humidity (reading is temperature compensated at entire temperature range):

Measuring range: 0 to 100 %RH (see Transmitter installation)

Resolution display: 0.1 %RH

Accuracy: ± 2.5 %RH from 5 to 95 %RH at 23 °C

Measuring temperature and humidity range is limited in accordance with the graph below

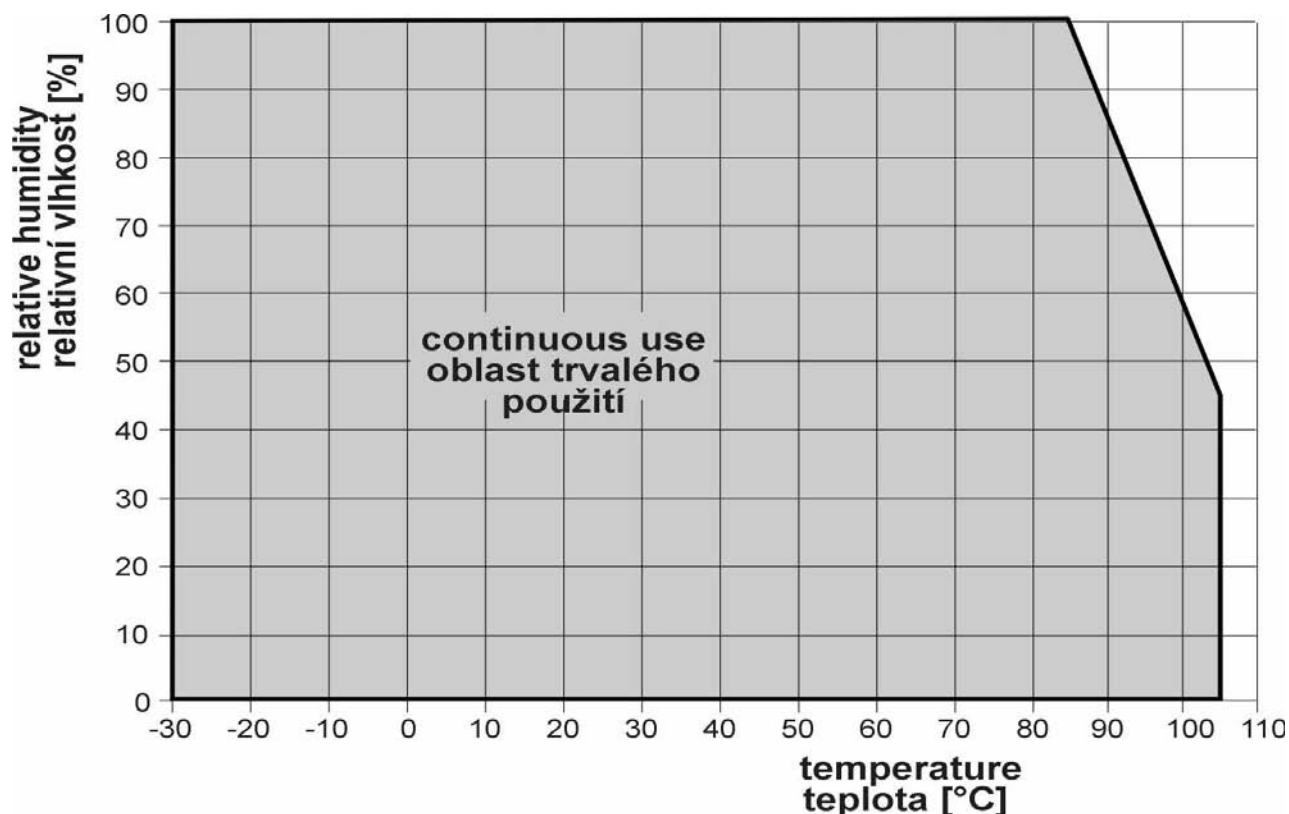

The value computed from air temperature and relative humidity:

Display resolution: 0,1 °C

You can choice one of the next value:.

Dew point temperature

Accuracy: ±1,5 °C at air temperature $T < 25^{\circ}\text{C}$ and $\text{RH} > 30\%$

Range: -60 to +80 °C

Absolute humidity

Accuracy: ±3g/m³ at air temperature $T < 40^{\circ}\text{C}$

Range: 0 to 400 g/m³

Specific humidity³

Accuracy: ±2g/kg at air temperature $T < 35^{\circ}\text{C}$

Range: 0 to 550 g/kg

Mixing ratio³

Accuracy: ±2g/kg at air temperature $T < 35^{\circ}\text{C}$

Range: 0 to 995 g/kg

Specific enthalpy³

Accuracy: ± 3kJ/kg at air temperature $T < 25^{\circ}\text{C}$

Range: 0 to 995 kJ/kg ⁴

³ This value depends on the atmospheric pressure. For computing is used constant value stored inside device memory. Default value preset by manufacturer is 1013hPa and can be changed by user's software.

⁴ This maximum is reached under conditions about 70°C/100%RH or 80°C/70%RH

Response time with stainless steel mesh sensor cover (F5200B) and bronze sensor cover (F0000 - selectable option), air flow approximately 1 m/s:
temperature: $t_{90} < 9$ min (temperature step 20 °C)
relative humidity: $t_{90} < 30$ s (humidity step 65 %RH, constant temperature)

Recommended calibration interval: 1 year

Measuring interval and LCD display refresh: 0.5 s

Power: 9 to 30 V dc

Consumption: max. 0.5W

Protection of the case with electronics and terminals: IP65

Protection of the sensor cover: IP40

Filtering ability of the sensor cover: 0.025 mm

Operating conditions:

Operating temperature range of case with electronics: -30 to +80 °C, over +70°C switch LCD display OFF

Operating temperature range measuring tip with sensors: -30 to +105 °C, cable max. 80°C, for special request it is available with cable to +105°C.

Operating relative humidity range: 0 to 100 %RH

Outer influence in accordance with EN 33-2000-3: normal environment with those specifications: AE1, AN1, AR1, BE1

Working position: negligible (see Transmitter installation)

Electromagnetic compatibility: complies EN 61326-1

Not allowed manipulation

It is not allowed to operate the device under conditions other than specified in technical parameters. Devices are not designed for locations with chemically aggressive environment. Temperature and humidity sensors must not be exposed to direct contact with water or other liquids. It is not allowed to remove the sensor cover—to avoid any mechanical damage of the sensors.

Storing conditions: temperature -30 to +80 °C, humidity 0 to 100 %RH without condensation

Dimensions: case with electronics 89 x 73 x 37 mm

Weight: approximately 175 g

Material of the case: ABS

End of operation

Device itself (after its life) is necessary to liquidate ecologically!

Technical support and service

Technical support and service is provided by distributor. For contact see warranty certificate.

Appendix A

Connection of ELO E06D converter (RS232/RS485)

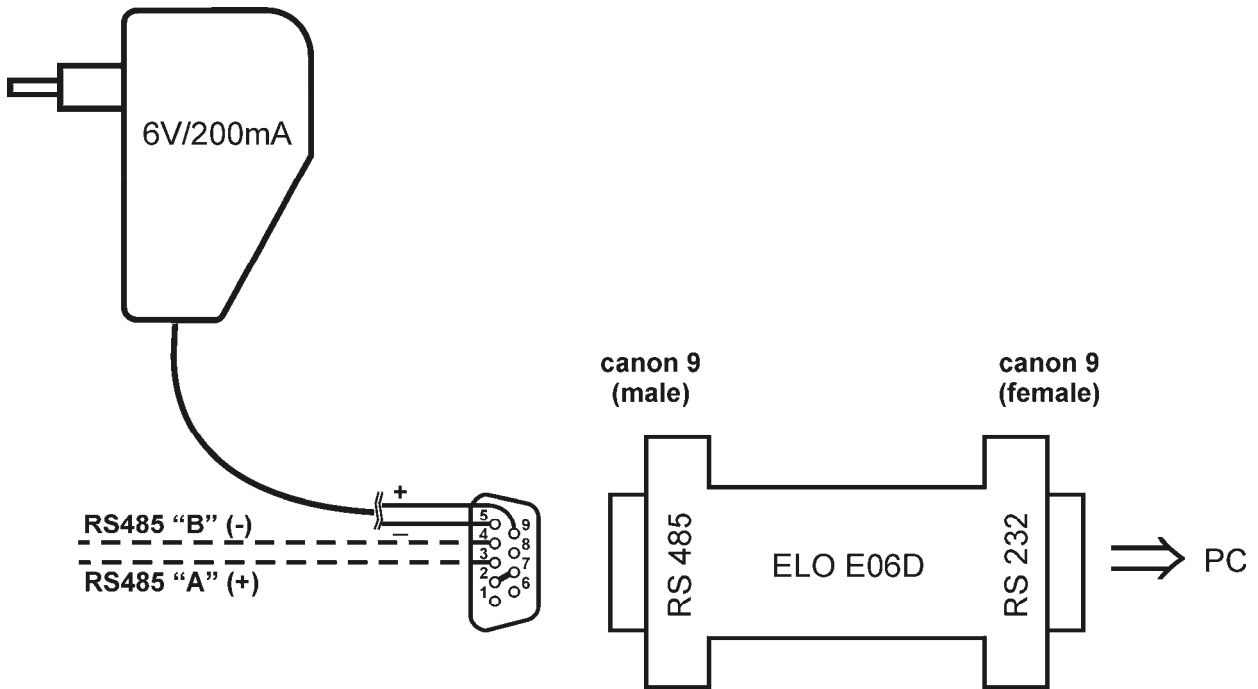

The ELO E06D converter is an optional accessory for connection of transmitter/transmitters with RS485 interface to the PC via serial port RS232. Connect connector marked RS232 directly to the PC, connect power to connector marked RS485. Power voltage **+6V DC** from an external acdc adapter connect to **pin 9**, **0V** connect to **pin 5**. Also mutually connect pin **2** and pin **7**. Link RS485 is connected across **pin 3 (A+)** and **pin 4 (B-)**.