

OPERATION MANUAL

Micro Computer Temperature Controller

WT404/409/707/904/909

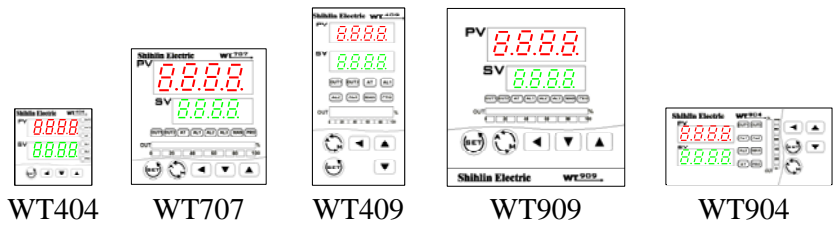

1 Attention

Before using please check whether range, input and output match your requirement.

⚠ Danger

Attention!

After electrifying, do not touch the terminal to prevent attacking!!

Please ensure the power has closed while you perform power wiring.

⚠ Warning

1. Please make sure the position of the rear terminal for AC power are correct, (WT404 for Pin1, 6 ; WT904/707/409/909 for Pin1,2)
2. Please ensure the voltage is the same with the spec (AC85~265 or DC 24V), or the controller would be damaged after electrifying.
3. Please ensure the wiring has connected to the right usage(Input, Output, Alarm) terminal.
4. Please Choose the terminal fitted the M3 , express as below:

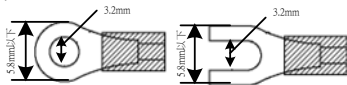

Torsion : 0.4 N.m (4 kgf.cm)

5. Do not set your controller under the surrounding with high interfere, caustic gas, and high temperature high humid. (normal working environment : 0~50°C , 50~85%RH) °
6. In order to prevent being interfered by noise, power wiring should leave from motivity power line and load power line.
7. While using down-lead for thermocouple, please choose the suited for thermocouple type.
8. While using down-lead for RTD, please choose samll , and use the same material for three line.

2 Panel Cut Dimension (Unit : mm)

WT404			
WT409			
WT707			
WT904			
WT909			

3 Front panel instruction

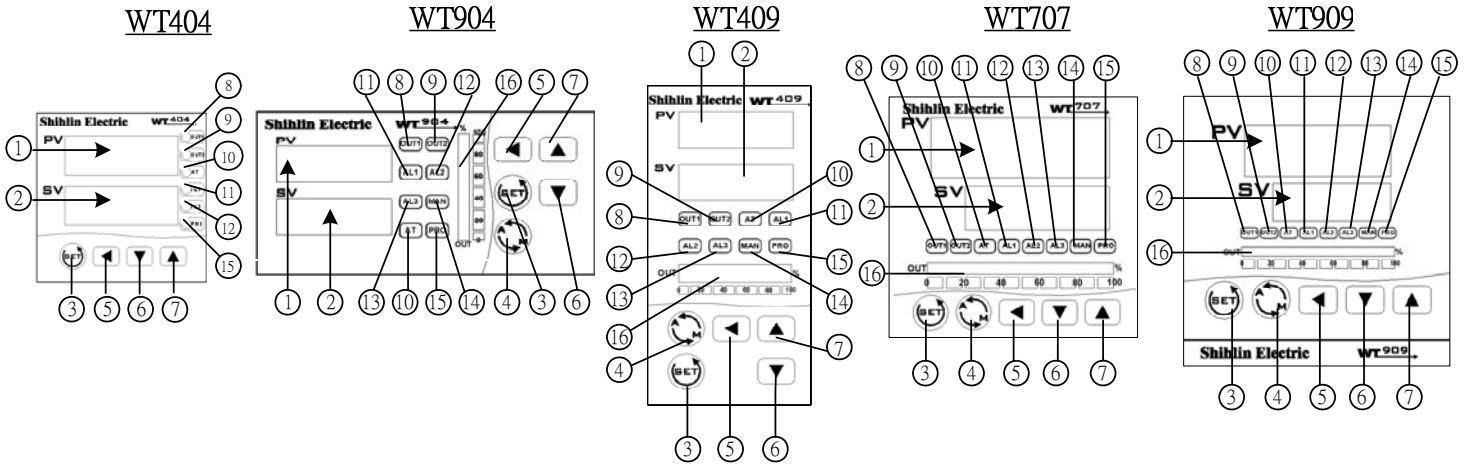

Symbol	Name	Explain
PV ①	Program Value	Display input
SV ②	SET Value	Display Set Value
③	SET key	MODE & SET
④	Auto/Manual key	Change auto(PID)input/ manual input
⑤	SHIFT key	Shift set value
⑥	DOWN key	Setting value -1, -10, -100, -1000
⑦	UP key	Setting value +1, +10, +100, +1000

LED	Name	Remarks
OUT1 ⑧	OUT1 Lamp	Output1, green color
OUT2 ⑨	OUT2 Lamp	Output2, green color
AT ⑩	Auto Tuning Lamp	Auto Tuning, yellow color
AL1 ⑪	Alarm1 Lamp	Alarm1, red color
AL2 ⑫	Alarm2 Lamp	Alarm2, red color
AL3 ⑬	Alarm3 Lamp	Alarm3, red color
MAN ⑭	Manual Lamp	Manual, yellow color
PRO ⑮	Program lamp	Program, yellow color
OUT% ⑯	Output percent	Display control input by LED

4 Wiring

WT404

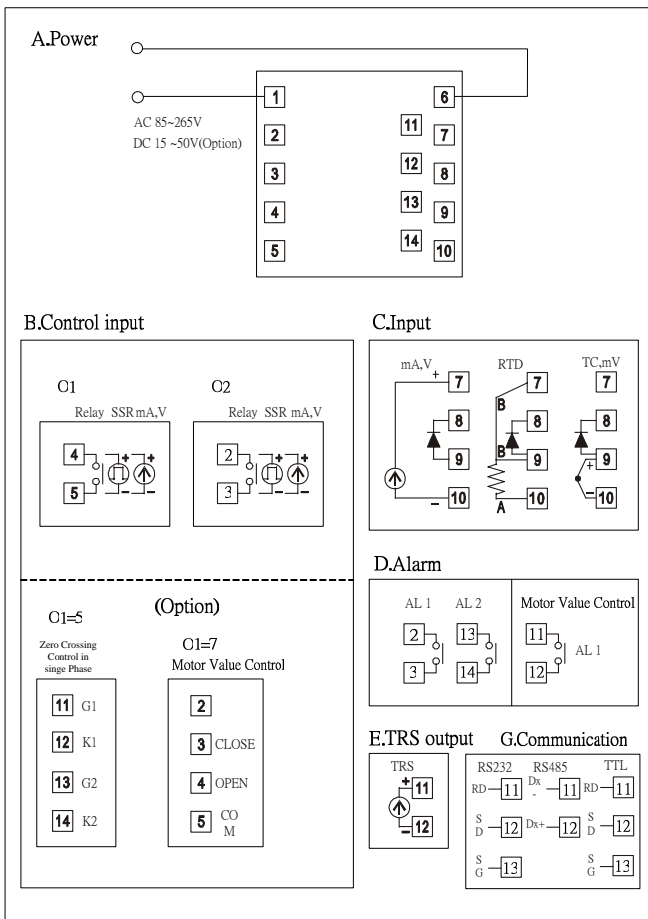

WT707

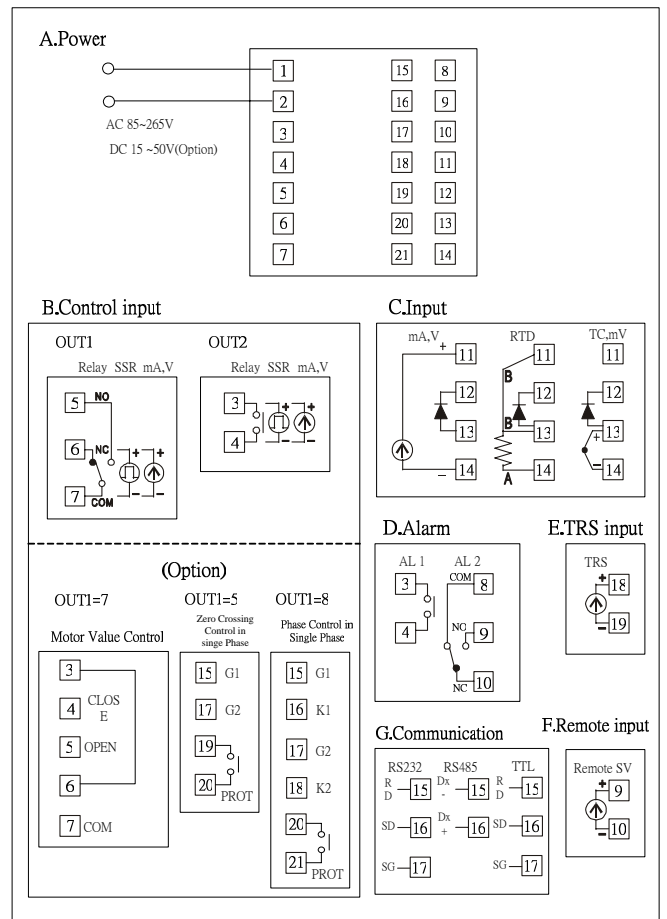

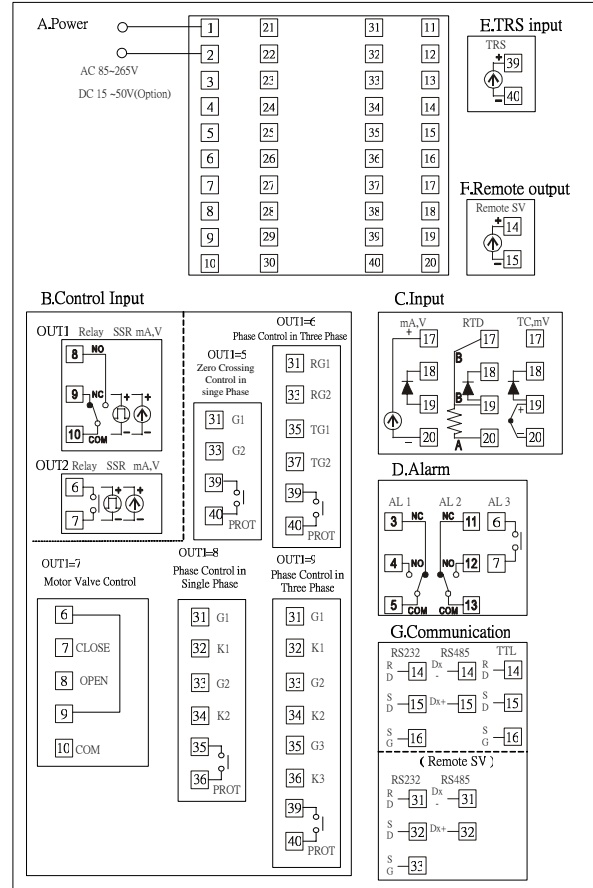
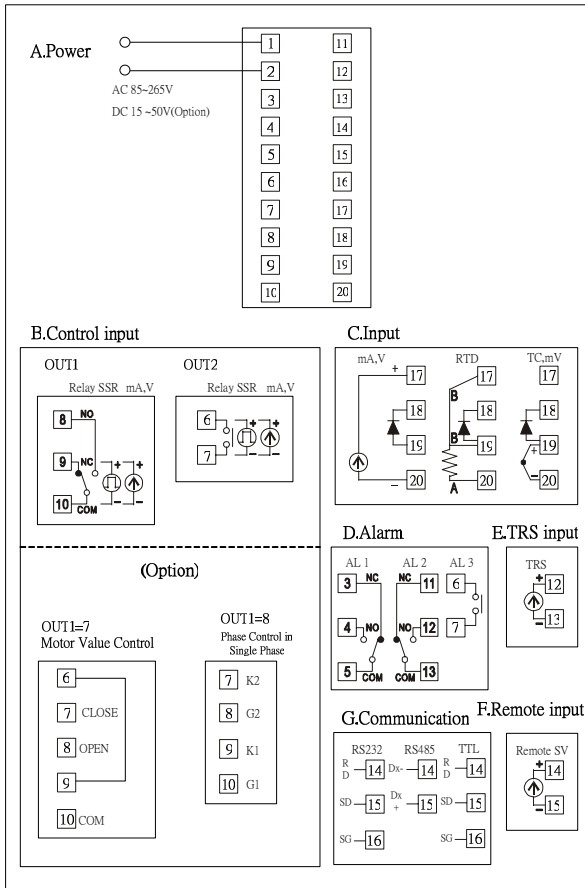

5 Operation step

1.Start

The control display by LED

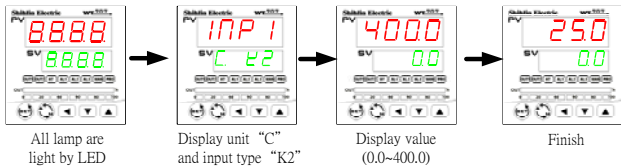

2.Set SV

Example :Set value =100

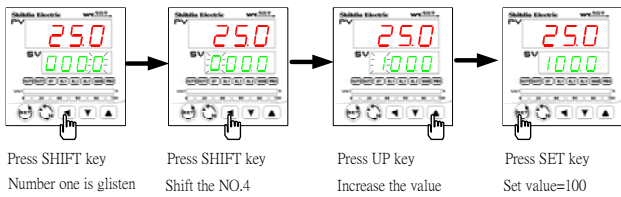

3.Auto Tuning

When AT™ is set to YES · auto tuning will start.

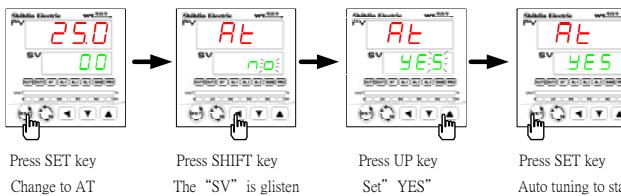

Auto Tuning Process
ATVL=0

Auto Tuning Process
ATVL=20

*Set ATVL avoid Overshoot produce at Auto Tuning Process

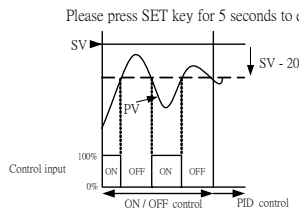
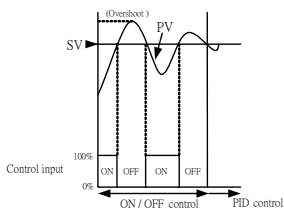

4.SET Alarm

Example: Set alarm value to "5" (When "PV" is higher then five, alarm1 action)

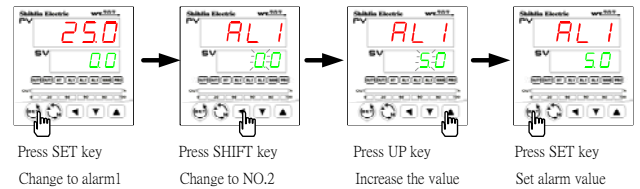

* When change alarm mode, please press "SET key" and "SHIFT key" to Level 3, set ALD1 paramter.

5.Alarm Mode

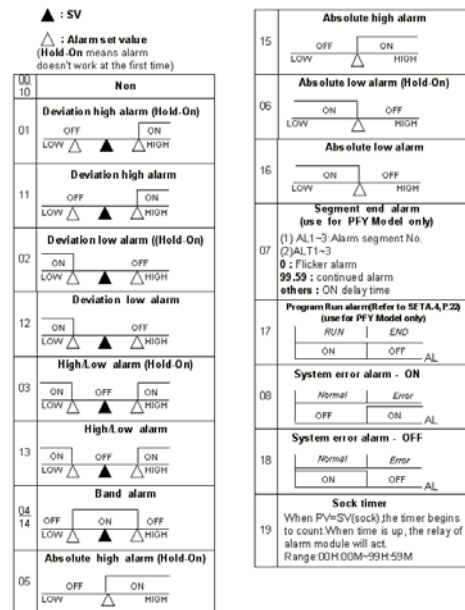

6 Factorial Parameter Instruction

Legend

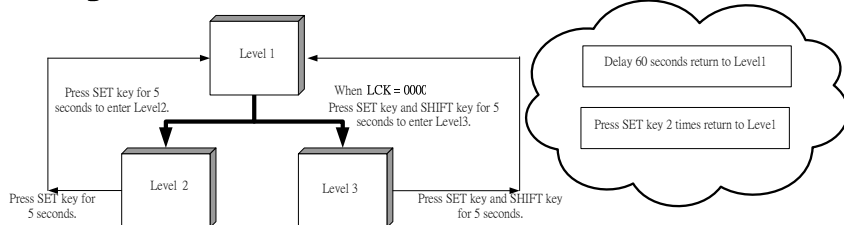

Level 1 (User Level)

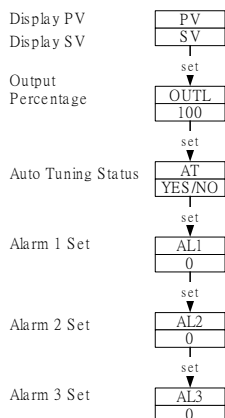

Level 2 (PID Level)

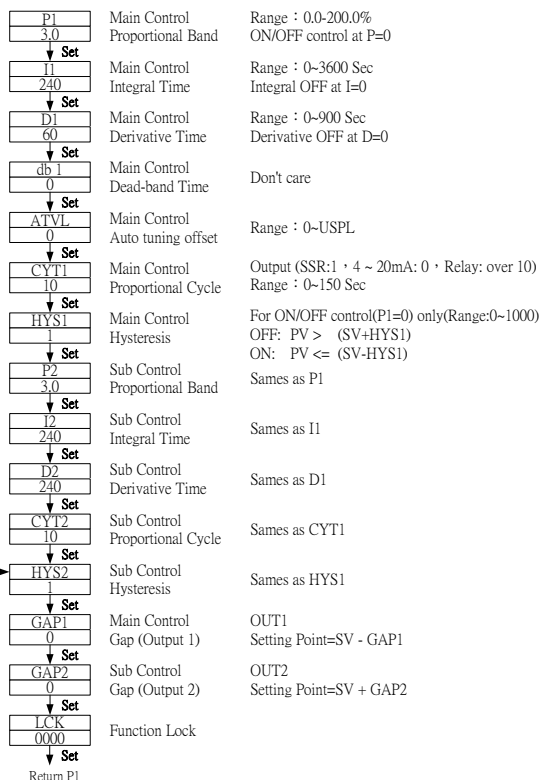

Displayed, only if P1=0.0
 Disappeared, only if Dead Output
 Displayed, only if P2=0.0

Level 3 (INPUT Level)

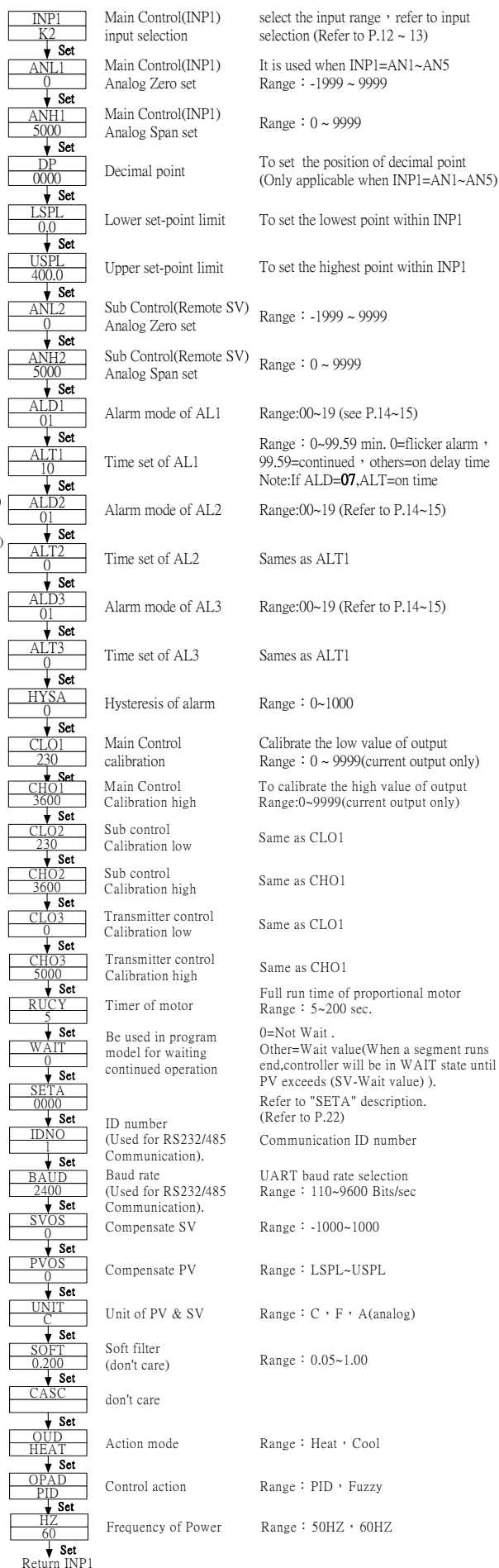

7 Error Message

in IE	IN1E : Input 1 Error Please check input signal
CJCE	CJCE :Cold Junction Compensation Failed Please check Cold Junction Compensation Diode
UUU1	UUU1 Input1 signal is higher then USPL Please check input signal and temperature range
nnn1	NNN1 Input1 signal is lower then USPL Please check input signal
AdCF	ADCF :A/D Convert Failed Please contact your vendor
RAMF	RAMF :RAM Failed Please contact your vendor