

## PRODUCT DESCRIPTION

**Programmable regulators** with Ethernet connection are designed to measure temperature, relative humidity and barometric pressure of air in non-aggressive environment, to signal alarms and to control of external devices. Three galvanically not isolated binary inputs are intended for detection of binary signals. These regulators are available in wall-mount version or with a probe on a cable. Type H3531P is designed to measure temperature and relative humidity of compressed air.

**The function of the two output relays** can be set from the device web pages and using jumpers (see „Electrical wiring“). The device allows two alarm limits to be set for each measured value. In response to the change of the alarm state a relay may be closed, an acoustic signal may be activated or an alarm message may be sent by email or other communication protocol. . The status of the output relays can be controlled remotely via Ethernet, too. Following computed values are supported - dew-point temperature, absolute humidity, specific humidity, mixing ratio, specific enthalpy and humidex. The currently measured values are shown on a two-line LCD display.

**Formats of the Ethernet communication** that are supported: HTTP – web, Modbus TCP protocol, SNMPv1, XML and SOAP protocol. Alarm messages are sent via email, SNMPv1 Trap or Syslog. To set all devices including their alarm limits embedded websites can be used. A device connected to a local network can be found by the *TSensor* software (free to download at [www.cometsystem.com](http://www.cometsystem.com)).

Type *	Measured values	Version	Mounting
<b>H0530</b>	T	ambient air	wall
<b>H4531</b>	T	external probe Pt1000/3850 ppm	wall
<b>H3530</b>	T + RH + CV	ambient air	wall
<b>H3531</b>	T + RH + CV	probe on a cable	wall
<b>H3531P</b>	T + RH + CV	probe on a cable – pressure up to 25 bars	wall
<b>H7530</b>	T + RH + P + CV	ambient air	wall
<b>H7531</b>	T + RH + P + CV	probe on a cable	wall

\* models marked HxxxxZ are custom - specified devices

T...temperature, RH...relative humidity, P...barometric pressure, CV...computed values

## INSTALLATION, OPERATION AND CONFIGURATION

The mounting holes and connection terminals are accessible after unscrewing the four screws in the corners of the regulator case and removing the lid. Place the device on a flat surface, pass the cables through released glands and connect wires according to the diagram (choose cables with external diameter of 4 to 6.5 mm and a wire cross-section of 0.14 to 1.5 mm<sup>2</sup>). Shielded cables have to be used for a two-state sensor and external probe connection (maximum cable length of 10 m). Insert attached plugs into unused cable glands, too. All cables should be located as separately as possible from potential interference sources. Pay attention to the device mounting, because incorrect choice of working position or measuring point could adversely affect the accuracy and long-term stability of measured values.

To connect the device to the network it is necessary to know a new suitable IP address. Please contact the network administrator to obtain the IP address. The device can obtain an IP address automatically from the DHCP server, or a static IP address can be set manually. The default IP address of devices is preset to **192.168.1.213**. After connecting the external probe, the Ethernet cable and the power adapter, the device IP address needs to be changed in the web pages. To change the IP address, the *TSensor* software can be used alternatively. The devices do not require special maintenance. We recommend verifying the measurement accuracy regularly by calibration.

## MONITORING AND VALUES RECORDING

For data monitoring and auditing it is recommended to use the Comet Database software. A trial version of Comet Database is available at [www.cometsystem.com](http://www.cometsystem.com). For monitoring, software and SCADA systems from third party vendors can be used. For data acquisition a communication protocol can be used which is supported by the device.

## ERROR STATES

The device continuously checks its state during operation. If an error appears, the relevant code is displayed: **Err 1** - the measured or calculated value (except of pressure) is above the upper limit, **Err 2** - the measured or calculated value is below the lower limit or a pressure measurement error has occurred, **Err 0**, **Err 3** and **Err 4** - a serious error has occurred, please contact the distributor of the device.

## SAFETY INSTRUCTIONS



- Do not use or store the devices without the cover of the temperature and humidity sensors.
- Temperature and humidity sensors should not be exposed to direct contact with water and other liquids.
- Take care when unscrewing the filter cap as the sensor element could be damaged.
- Use only a power adapter which is approved according to technical specifications and relevant standards.
- Do not connect or disconnect devices while power supply voltage is on.
- Do not install or remove the probe of the H3531P regulator under pressure.
- Installation, electrical connection and commissioning should be performed by qualified personnel only.
- The devices contain electronic components. Dispose of them in accordance with legal requirements.
- **To complement the information in this data sheet** read the manuals and other documentation, which are available in the Download section for a particular device at [www.cometsystem.com](http://www.cometsystem.com).

# Technical specifications

Device type	H4531	H0530	H3530, H7530	H3531	H7531	H3531P
Common parameters	<i>Supply voltage:</i> 9 to 30Vdc <i>Power consumption of the device:</i> ~ 1W <i>Relay outputs:</i> max. switching voltage ... 50V, max. switching current ... 2A, max. switching power ... 60VA <i>Binary inputs:</i> low level input voltage ... 0 to 0.5V, high level input voltage ... 3 to 30V, auxiliary power supply +U ... 9 to 30 Vdc					
Temperature measuring range	-200 to 600°C	-30 to +80°C	-30 to +80°C	-30 to 105 °C	-30 to 105 °C	-30 to 105 °C
Accuracy of temperature measurement	±0.2°C (without probe)	± 0.4°C	± 0.4°C	± 0.4°C	± 0.4°C	± 0.4°C
Relative humidity (RH) measuring range	—	—	0 to 100 %RH	0 to 100 %RH	0 to 100 %RH	0 to 100 %RH
Accuracy of humidity measurement from 5 to 95 %RH at 23°C	—	—	± 2.5 %RH	± 2.5 %RH	± 2.5 %RH	± 2.5 %RH
Barometric pressure measuring range	—	—	600 to 1100 hPa (H7530)	—	600 to 1100 hPa	—
Accuracy of barometric pressure measurement at 23°C	—	—	±1.3hPa (H7530)	—	±1.3hPa	—
Other calculated humidity variables (dew point temperature, ...)	—	—	yes	yes	yes	yes
Recommended calibration interval of the device *	2 years	2 years	1 year	1 year	1 year	1 year
Protection class of the case with electronics	IP40	IP40	IP40	IP40	IP40	IP40
Protection class of the sensors cover	—	IP40	IP40	IP40	IP40	IP40
Temperature operating range of the case with electronics **	-30 to +80°C	-30 to +80°C	-30 to +80°C	-30 to +80°C	-30 to +80°C	-30 to +80°C
Temperature operating range of the sensing element (sensors)	—	-30 to +80°C	-30 to +80°C	-30 to +105°C	-30 to +105°C	-30 to +105°C
Humidity operating range	0 to 100%RH	0 to 100%RH	0 to 100%RH	0 to 100%RH	0 to 100%RH	0 to 100%RH
Mounting position	any position	sensor cover downwards	sensor cover downwards	any position ***	any position ***	any position ***
Storage temperature range ( 0 to 100%RH, no condensation)	-30 to +80°C	-30 to +80°C	-30 to +80°C	-30 to +80°C	-30 až +80°C	-30 to +80°C
Electromagnetic compatibility according to	EN 61326-1	EN 61326-1	EN 61326-1	EN 61326-1	ČSN EN 61326-1	EN 61326-1
Weight	340 g	340 g	360 g	410 (450, 530) g	410 (450, 530) g	460 (500, 580) g
Dimensions [mm]						

## Electrical wiring

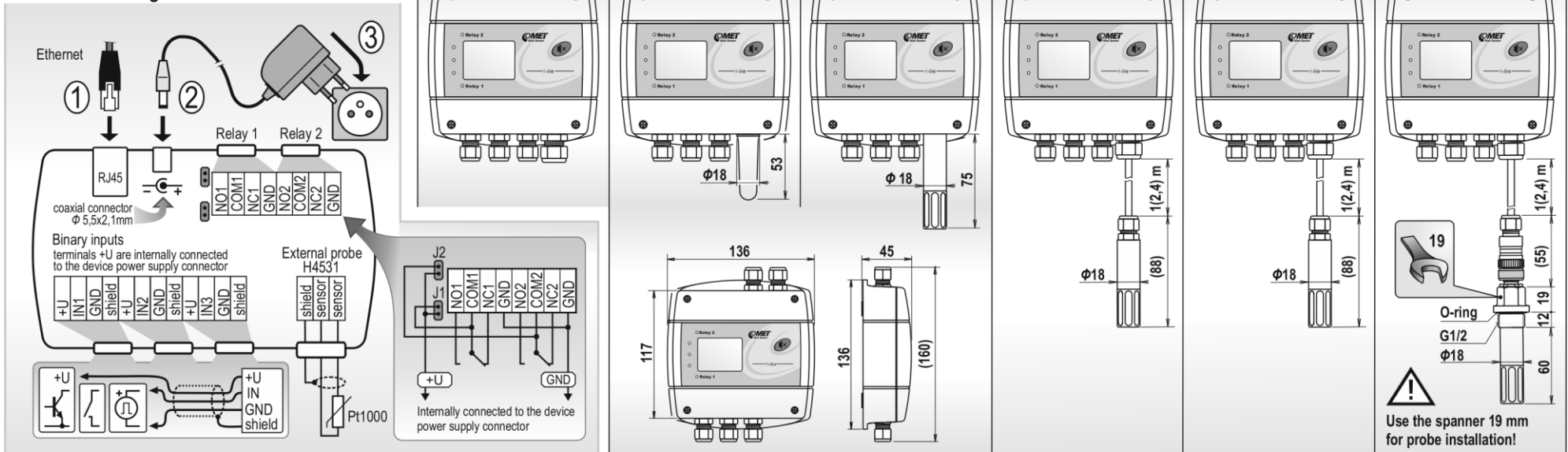

\* The relative humidity measuring range is limited at temperature above 85°C, see manuals for devices  
 \*\* Recommended calibration intervals: relative humidity - 1 year, temperature - 2 years, pressure - 1 year

\*\*\* It is recommended to switch off the LCD display at ambient temperature above 70°C  
 \*\*\*\* if it can lead to long term condensation of water, it is necessary to use the probe at position with sensor cover downwards